

correa

FENIX

Travelling column milling machine

WARRANTY



Nicolás Correa, founded in Spain in 1947, is one of world's leading companies in the manufacturing of large milling machines. With over 900 bridge type machines, 1000 floor type machines and 3500 bed type machines installed all over the world, offers milling solutions designed for the most demanding production environments, such as the power generation, automotive, aerospace and railway industries.

Nicolás Correa is the parent company of **Correa Group** composed of four industrial subsidiaries linked to the machine tool sector: Hypatia, Steelworks, Electrónica and Kunming. The Group has commercial subsidiaries in China, Germany, United States, and India with the aim to offer the best service in all countries. Belonging to the group provides **Nicolás Correa** with access to top quality critical supplies and offers tailored solutions especially designed for each customer's needs.

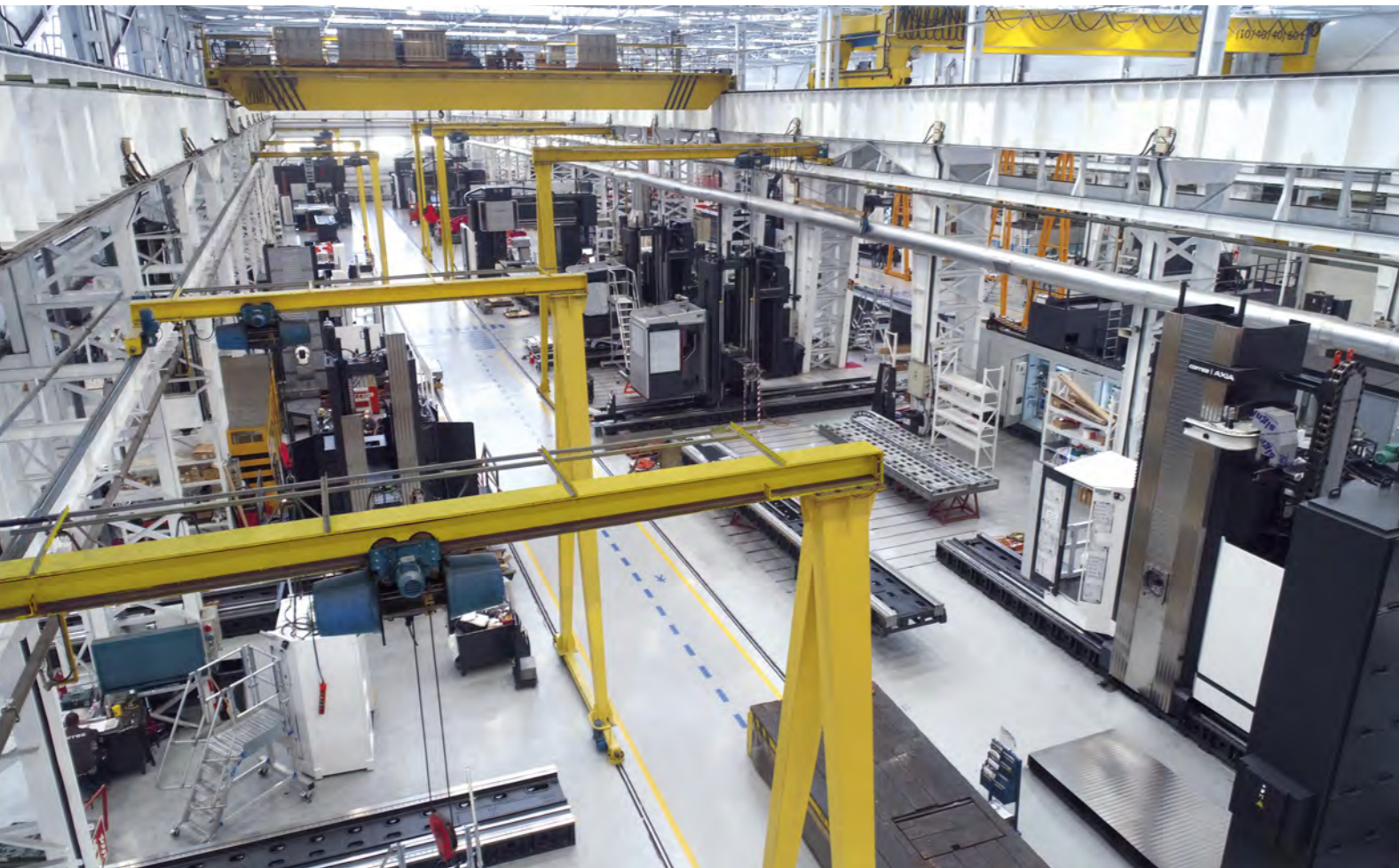

Thousands of customers around the world place their trust in **correa** range of milling machines. **Correa Group** currently exports around 90% of its production to over 30 different countries. To guarantee a high-quality service to our customers, we have an extensive international commercial and technical service network in most of the world's countries. **Correa Group** offers the widest range of milling solutions on the market, including bed type machines, gantry, floor type machines, bridge type machines, it also has a several options of multi-tasking machines. The entire range is designed and manufactured in Spain. **Nicolás Correa, S.A.** has been listed on the Madrid Stock Exchange since 1989.

The **FENIX** represents a new concept of travelling column machine with lateral ram. Highly robust based on a system of L-guided ram. High precision thanks to the mechanical system of ram droop correction. A flexible machine appropriate for roughing and finishing operations.



L-GUIDE-WAY SYSTEM CONFIGURATION

- L-shape guiding system:
 - Greater rigidity and stability during machining.
 - Greater geometric precision.
 - Less ram droop effect.
- 6 sliding blocks in the vertical movement guaranteeing good performance of the machine.

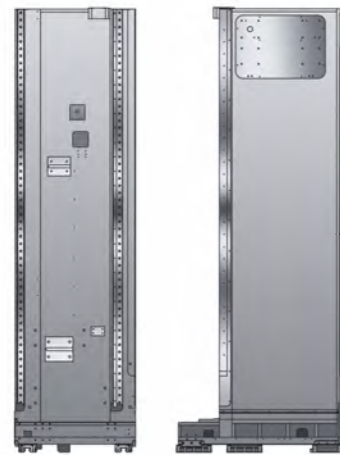
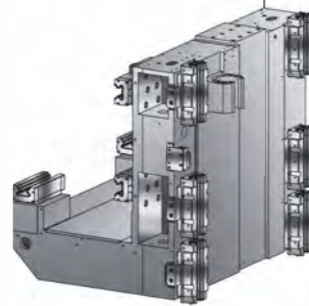
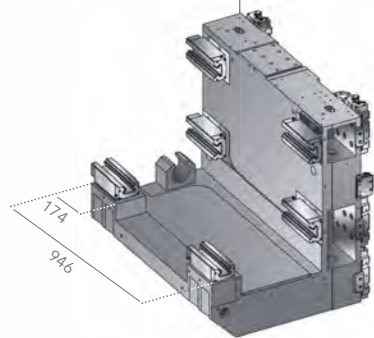

Longitudinal saddle integrated in the machine column as a single monolithic part.

- Maximum sturdiness.
- Maximum geometric precision.
- Minimum column shift error.
- Maximum machining stability.



MECHANICAL COMPENSATION SYSTEM

Traction bars to eliminate angular error of the ram droop effect

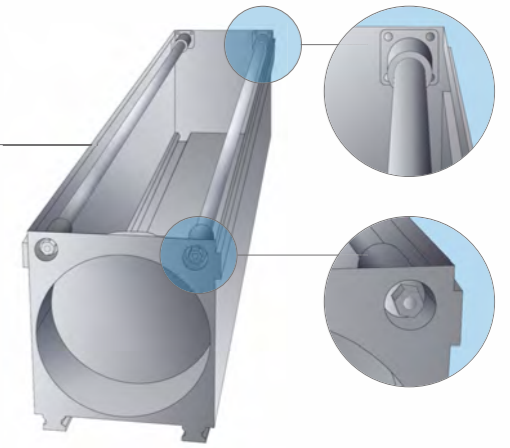

Direct transmission of drive to vertical axis to guarantee maximum sturdiness and precision

Ram with generous cross section equipped with 3 guide-ways ensuring the maximum accuracy and robustness



OVERSIZED STRUCTURAL ELEMENTS

Roughing capacity + Machine geometry stability



HIGH GEOMETRICAL PRECISION

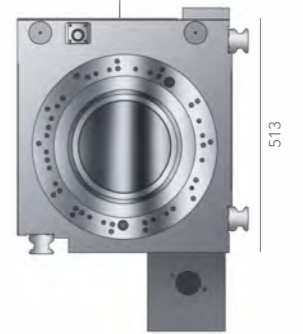

470

513

MORE ABOUT THE **FENIX**



Dynamic performance parametrizable in accordance with:

- ROUGHING OPERATION
- FINISHING OPERATION



MACHINE DYNAMIC ADJUSTMENT



MACHINING SETTINGS



ROUGHING

FINISHING

25 m/min feed in the X, Y and Z axes, thanks to the linear guide system



HIGH FEED RATES



ECO DESIGN

Stand-by function and Auto Switch off function, saving 20% of the total energy machine consumption

Technical Features

TABLE

Surface	4800 x 1000 / 23000 x 3000	mm
Maximum load on the table	10 / 15	t/m ²

TRAVERSES

Longitudinal [X]	4500 + 1500 x N	mm
Cross [Y]	1250 / 1500	mm
Vertical [Z]	1500 / 2000 / 2300 / 2500 / 3000	mm

FEEDS

Maximum [X]	25	m/min
Maximum [Y]	25	m/min
Maximum [Z]	25	m/min

SPINDLE SPECIFICATIONS

Spindle nose	ISO-50 Big Plus / HSK-100	
Programmable speed	10000 / 6000	rpm
Maximum power	42 / 33 / 43	kW
Maximum torque	620 / 990 / 1291	Nm

External Dimensions

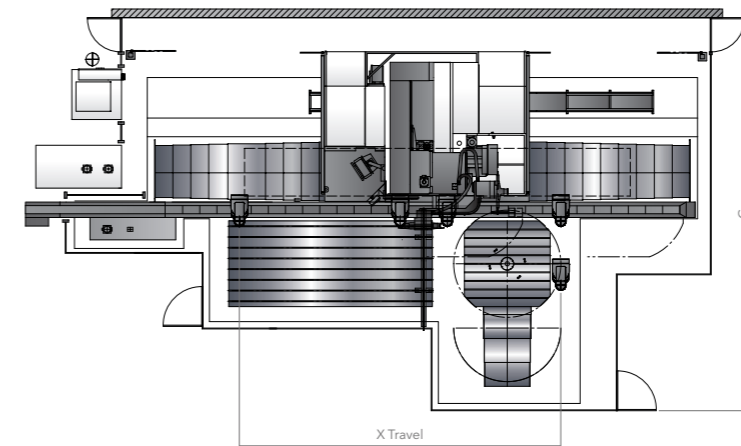

Y Travel	Table width	G
1250	2000	6915
	2500	7415
1500	2000	7165
	2500	7665

Z Travel	TMH	THTC		
		ATC 60	ATC 80	ATC 100
1500	4080	4850	4440	-
2300	5525	4850	5200 (1)	5900 (2)

X Travel	A	B	C [Buried]		D [Buried]		P
			0	675	0	675	
4500	6000	9520	11000	11675	12245	12920	2130
6000	9000	11070	12500	13175	13745	14420	3630
7500	9000	12520	14000	14575	15245	15920	3630
9000	12000	14070	15500	16175	16745	17420	5130
10500	12000	15520	17000	17675	18245	18920	5130
12000	15000	17070	18500	19175	19745	20420	6630
13500	15000	19520	20000	20675	21245	21920	6630
15000	18000	21070	21500	22175	22745	23420	8130
16500	18000	22970	23000	23675	24245	24920	8130
19500	21000	26470	26000	28675	27245	27920	9630
22500	24000	29970	29000	29675	30245	30920	11130
25500	27000	33420	32000	32675	33245	33920	12630

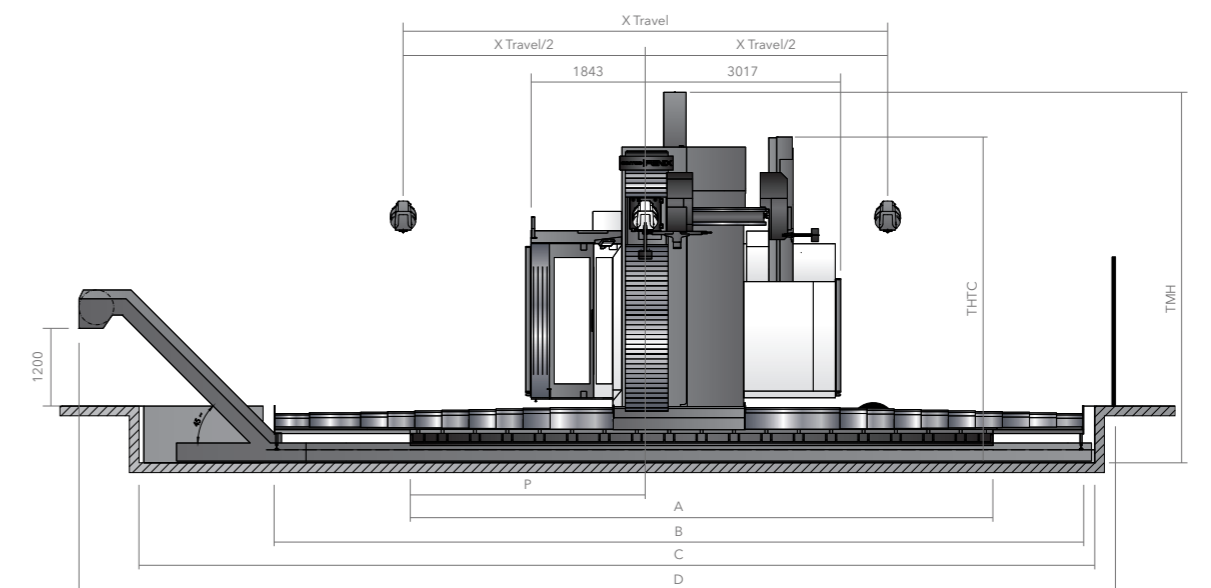

FENIX

Travelling column milling machine



Milling Heads

UAD 0.02° x 0.02°



Universal Auto-Indexing
Differential Head
33 kW | 990 Nm | 6000 rpm
43 kW | 1291 Nm | 6000 rpm



FC-30

Front Spindle
33 kW | 990 Nm | 4000 - 6000 rpm
43 kW | 1291 Nm | 4000 - 6000 rpm



OAD 0.02° x 0.02°

Orthogonal Auto-Indexing
Differential Head
33 kW | 990 Nm | 6000 rpm
43 kW | 1291 Nm | 6000 rpm

UDX 0.02° x 0.02°



Universal Auto-Indexing Head
42 kW | 620 Nm | 10000 rpm

Standard Equipment

- Automatic Universal Head
- Hydraulic and cooling group
- Numerical control Heidenhain or Siemens [operate HMI]
- Absolute Heidenhain measurement rules in all axes
- Portable handwheel
- Exterior coolant with adjustable lance nozzles
- Air-conditioned electrical cabinet
- Internal and external air flow
- Linear guides in the X, Y, Z axes
- Guarding
- Lamp in the working area
- Tele-service

Optional Equipment

- Other heads
- Vixion 4.0
- Pick up station for 8 and 12 tools
- Self cleaning filter
- Automatic changer for 30, 40, 60, 120 tools
- Air/Coolant cleaning gun
- Probes of measurement, tools and parts
- Chip conveyors
- Rotary tables
- Perimeter fence
- Turning tables
- Different enclosures according to user's needs [only in some models]
- Floor plates
- Coolant through the spindle

FENIX

Travelling column milling machine





MULTITASKING

correa multitasking machines combine several cutting processes on one machine. These machines offer the manufacturing capabilities of milling and turning machines into one integrated unit to use the functionality of both simultaneously.

UAD T

The universal head **UAD T** incorporates a spindle internal brake to lock the spindle axis. This solution allows to rotate the turning tool to any position and lock the spindle accordingly. This is a mechanical transmission head providing a perfect integration between milling and turning.



General Specifications

Tool holder HSK-100 for both milling and turning tools. In case of turning tools HSK-100T is required.

Milling mode: 6000 rpm and rotation every 0.02° in both bodies.

Turning mode: Rotation every 0.02° in both bodies.

TU

Orthogonal turning head **TU** rotates every 2.5° thanks to the crown hirth coupling allows to position the tools. We can use neutral tools for turning providing the angel with the head position, reducing the number of tools needed.



General Specifications

Tool holder Capto C8.

Rotation every 2.5° to reduce the number of turning tools to be used.

Automatic tool changing.

TU 25

Turning head **TU 25** incorporates two tapers to 90°. The two tapers offer flexibility to perform several facing and turning operations on a workpiece.



General Specifications

Tool holder Capto C8.

Double two tapers to 90°.

Manual tool change.

	Material	Ø (mm)	Ap (mm)	Vc (m/min)	F (mm/min)	Q (cm ³ /min)
Medium Duty Roughing	Ck-45 (60 kg/mm ²)	1090	4.5	210	0.5	471
Heavy Duty Roughing	Ck-45 (60 kg/mm ²)	1200	10	210	0.7	1450

TUB

For internal turning operations in deep parts, Nicolás Correa has specifically designed a manual extension which includes a tuned mass absorber (TMA) internally for a better cutting performance.

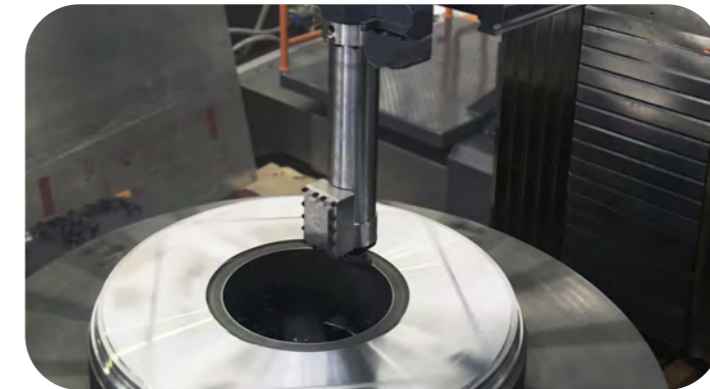

TURNING ROTARY TABLE

	Ø 1600 mm	Ø 2000 mm	Ø 2500 mm	Ø 3000 mm	
Maximum load milling/turning	6	20	30	60	t
Speed	250	150	120	100	rpm



correa

www.nicolascorrea.com

Nicolás Correa, S.A.

Alcalde Martín Cobos, 16-A
09007 Burgos • Spain

Phone: +34 947 288 100

Fax: +34 947 288 117

correa@correa.es

