

# BLOCK-SC

SELF-CENTERING  
STATIC  
BLOCKS

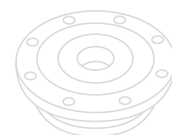
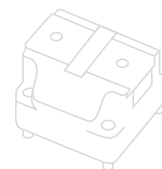
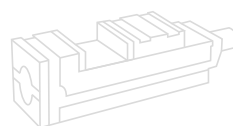

**fresmak**

## AT FRESMAK INNOVATION IS NOT AN OPTION IT IS OUR ATTITUDE

Fresmak was founded in 1967 focused on manufacturing high pressure vices.

Nowadays, it has a wide range of clamping solutions and exports to over 50 countries worldwide.

Above all, Fresmak are people. Highly trained professionals with a constant attitude to improve and innovate in all processes; from planning right up to its implementation at customers facilities.

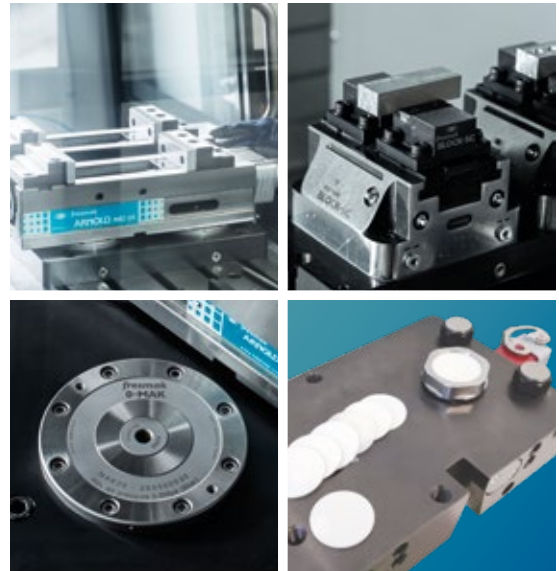

## SPECIALIST IN CLAMPING SOLUTIONS

### ARNOLD

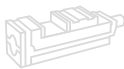

### BLOCK-SC



### 0-MAK



## A STRATEGIC LOCATION FOR A FAST AND EFFICIENT SERVICE

Germany · Argentina · Australia · Austria · Belgium · Brazil · Canada  
Chile · Colombia · Denmark · USA · Slovakia · Slovenia · Spain · Estonia · France · Finland · Greece  
Holland · Hungary · India · Iceland · Ireland · Italy · Luxembourg · Mexico · Norway · Peru · Poland  
Portugal · United Kingdom · Czech Republic · Dominican Republic · Romania · Russia · Singapore  
Sweden · Taiwan · Turkey · Ukraine · Venezuela





## EXPERIENCE

Fresmak is the first high pressure vice manufacturer in the world, focused ever since exclusively on clamping through a constant feedback from its clients.

This has allowed Fresmak to acquire a degree of knowledge and experience that guarantees its customers the **best solution** for clamping their workpieces.

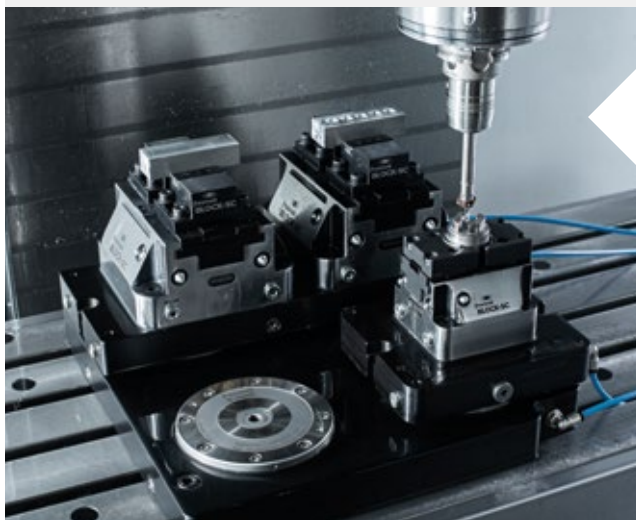

## SPECIALIZATION

Fresmak has a wide and **complete range** of clamping solutions, both standard and tailor made.

The company is constantly investing in R + D + i and is involved in innovation projects, both nationally and internationally, where it is considered a specialist in clamping.

## SERVICE

Fresmak offers a **direct and individual attention** to all its customer.

It also answers quickly and flexibly to offers as well as to orders.

Repair and maintenance service are also available for customers.



## KEYS THAT HELP FRESMAK BECOME A WORLDREFERENCE IN CLAMPING SOLUTIONS

- Absolute expertise in the product.
- A team of highly qualified and experienced people.
- Latest technology.
- Constant R & D investment.

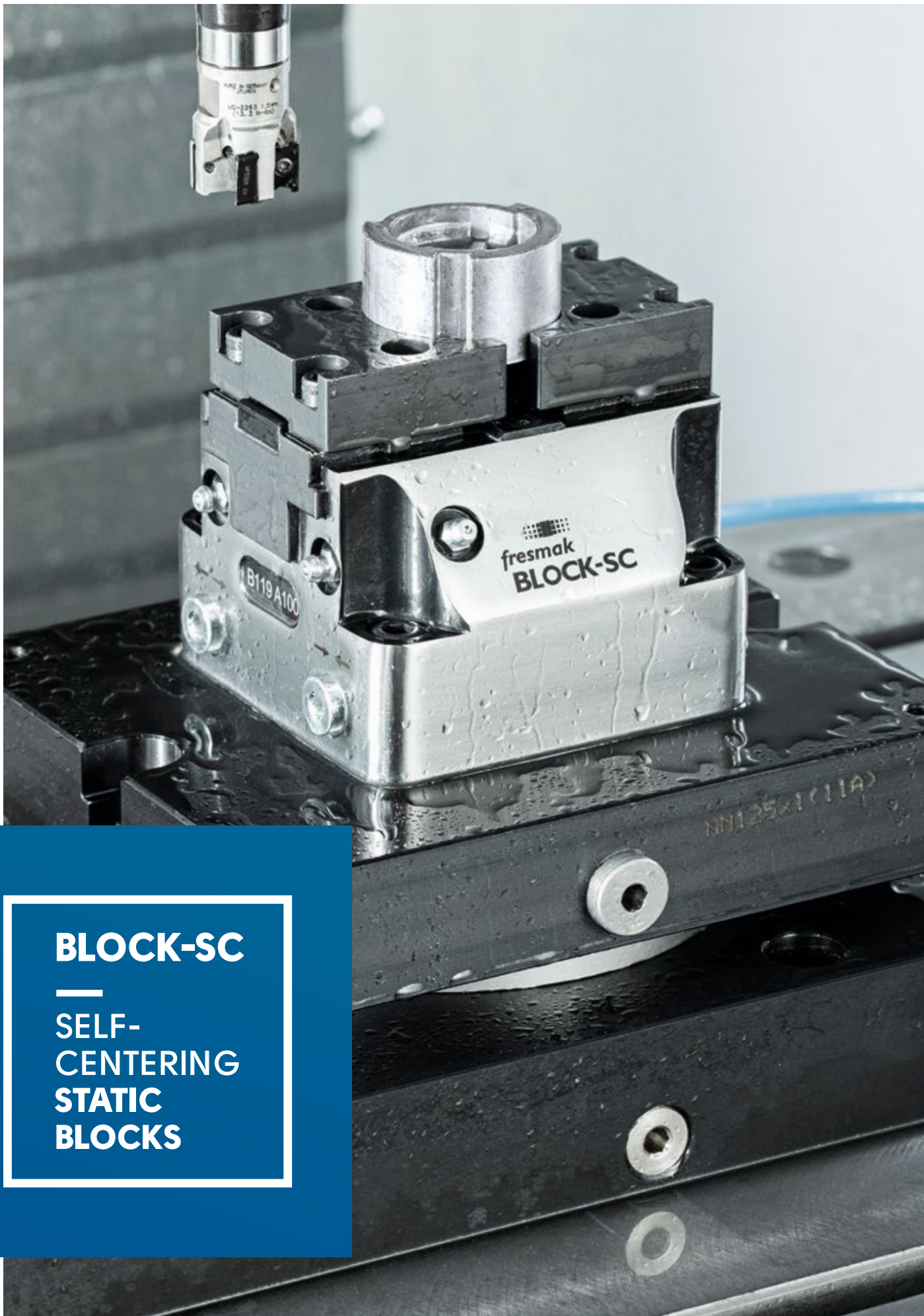

## **BLOCK-SC**

—  
**SELF-  
CENTERING  
STATIC  
BLOCKS**

# Index



Fresmak: Smart Clamping

1-2



## BLOCK-SC

5

The system

5

Functioning

7

Block-SC Hydraulic

9

Block-SC Pneumatic

13

Parts and accessories

17



Jaws

17



Plates

19



Tailor made

21



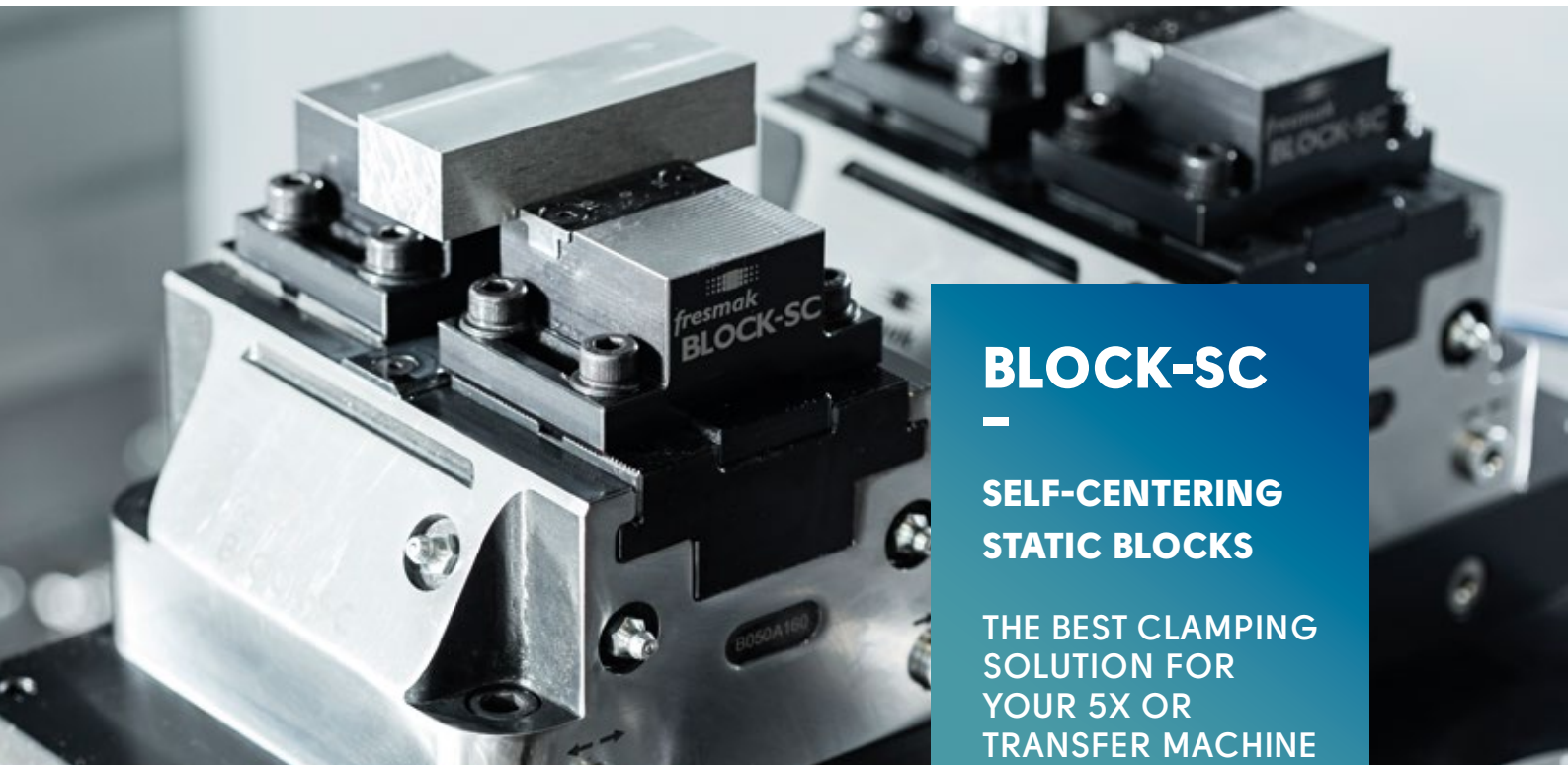

# BLOCK-SC

## SELF-CENTERING STATIC BLOCKS

THE BEST CLAMPING  
SOLUTION FOR  
YOUR 5X OR  
TRANSFER MACHINE

### » AUTOMATIC CLAMPING

When machining short series, as well as for medium and long batches in confined spaces through an automatic clamping, the use of self centering clamping chucks is very much recommended.

### RESISTANT

Constructed in high strength steel, its hermetic structure is watertight to chips and coolants.

### OPTIMUM DESIGN

Due to its compact design, allows optimum use in multi axis machines with total access to all sides of the part, making possible the use of short tools. A number of BLOCK-SCs can be assembled one next to the other using minimum space. This allows to optimize the use of the table.



### BLOCK-SC FEATURES

- |               |          |
|---------------|----------|
| 1 Cover plate | 5 Body   |
| 2 Wedge       | 6 Piston |
| 3 Key         | 7 Cover  |
| 4 Guide jaw   |          |

### QUICK

These blocks combine clamping strength with a long automatic advance and return stroke for a faster change of the work-piece. BLOCK-SC guarantees thousands of clamps without any misshape and assuring the highest precision in positioning and repeatability. This makes it suitable for medium and large batches.

## CONTROL AND VERIFICATION

Each unit of BLOCK-SC has a single identification number that contains all the data of the product, such as dimensions, tolerances, batch and serial numbers, as well as, production date. The data collection is made through a dimensional control, which is later recorded within the database of Fresmak.

Finally, they are individually verified either with oil or air, depending on the model.

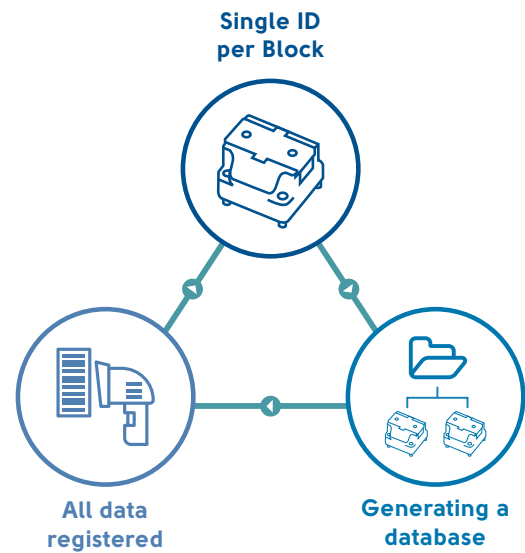

## TYPES: HYDRAULIC AND PNEUMATIC

At Fresmak there are two types of BLOCK-SC, pneumatic and hydraulic, both with double effect actuating.

### BLOCK-SC Hydraulic

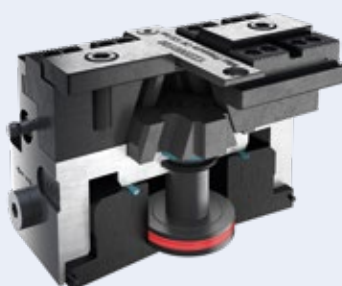

HYDRAULIC BLOCK-SC are oil actuated with an infeed power of up to 120 bar and designed for reaching a pressure up to 40 KN.

### BLOCK-SC Pneumatic

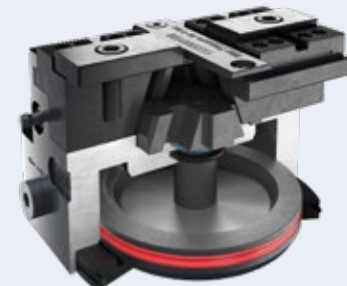

PNEUMATIC BLOCK-SC are air actuated with an infeed power of up to 9 bar and designed for reaching a pressure up to 20 KN.

## BLOCK-SC FUNCTIONING

### 1 Infeed

It is fed through the base or side holes.

○ Feed holes



### 2 Opening

When the wedge moves upwards guide jaws are opened.

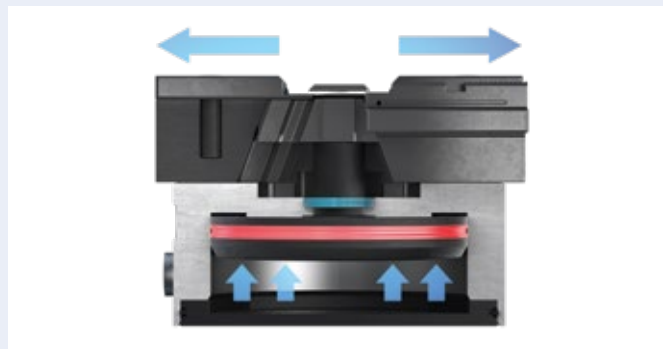

### 3 Closing

When the wedge moves downwards guide jaws are closed.

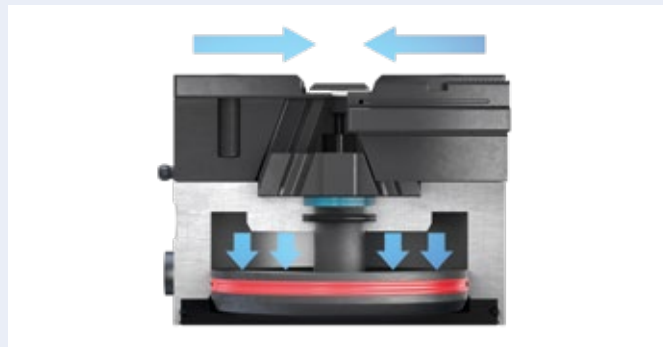

**!** The BLOCK-SC allows external as well as internal clamping.

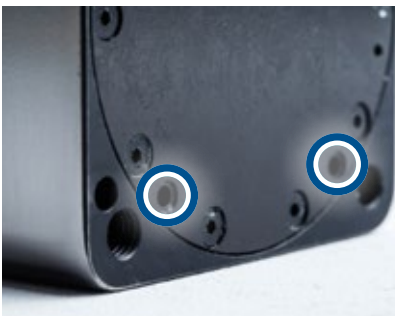

### Lubrication

○ Lubrication points



## Applications

When machining in a transfer machine, several plates can be placed covering the table and allowing us to save machine downtime, since the BLOCK-SCs can clamp a large number of parts.

## BLOCK-SC ARE SPECIALLY AIMED AT MASS PRODUCTION OF SMALL WORKPIECES

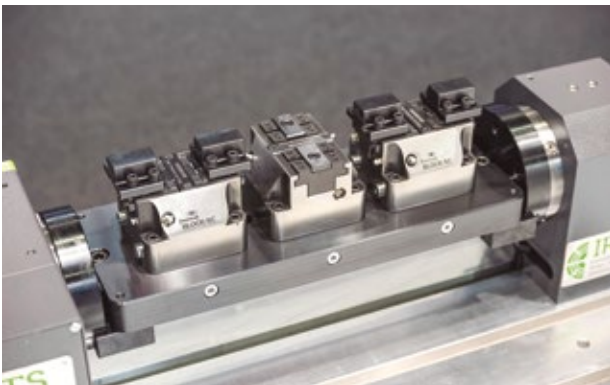
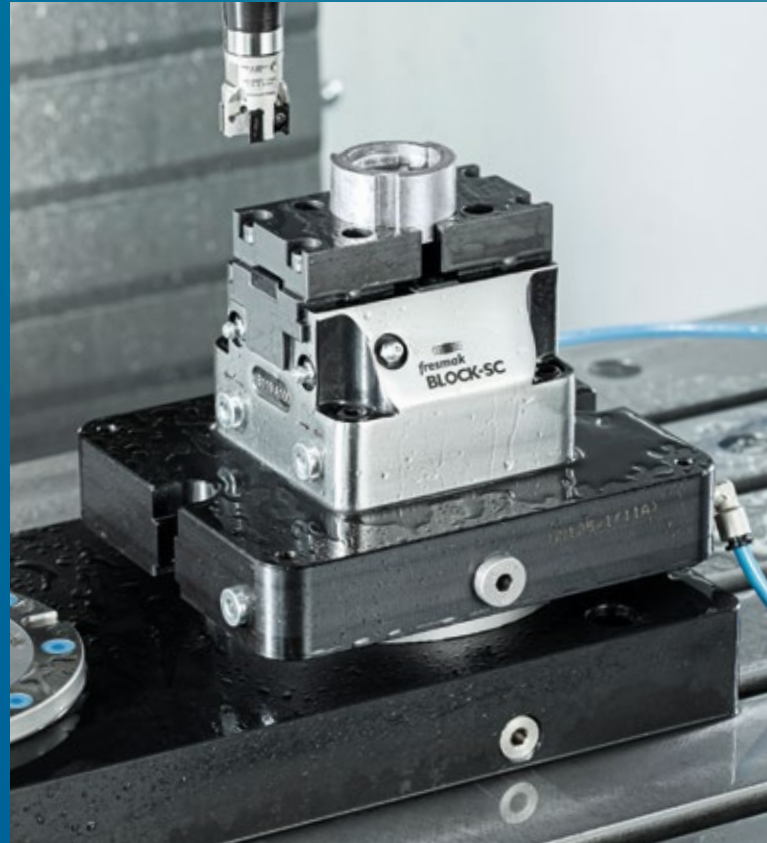

Another common application is in vertical machining centers to which we can add a fourth axis. Normally, by using a rotary table and a plate with some BLOCK-SCs in both faces, saving machine downtime.



Also 5 axis machines have taken a leading role since we can clamp a part with very little clamping surface, allowing full access to all sides, with short tools, being the part finished with a single clamp.

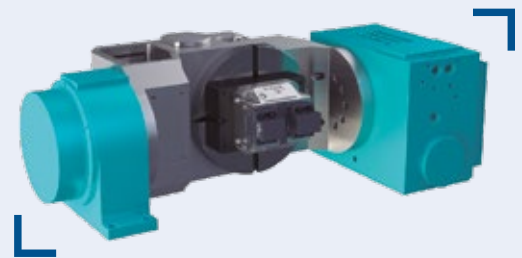

# BLOCK-SC Hydraulic



Hydraulic **BLOCK-SC** static blocks reach a pressure up to 40 KN with an infeed power of 120 bar.

## SET SUPPLIED

- Body
- 2 body dowel pins
- 4 screws
- Service manual

## FUNCTIONING

→ Hydraulically driven wedge clamping system: the multiplication of the hydraulic force is performed by actioning the wedge.

## FEATURES

- > Stroke range of 6 and 8mm.
- > Double effect actinoning.
- > Long guides.
- > All basic components are hardened.
- > Basic surfaces are ground.
- > Entirely compact and fully protected against chips.
- > Total lubrication system. Greasing channels within the base jaw and base body.
- > The oil supply for machining and lubrication can be performed from the sides or the base of the body.
- > Hydraulic supply up to 120 bar.

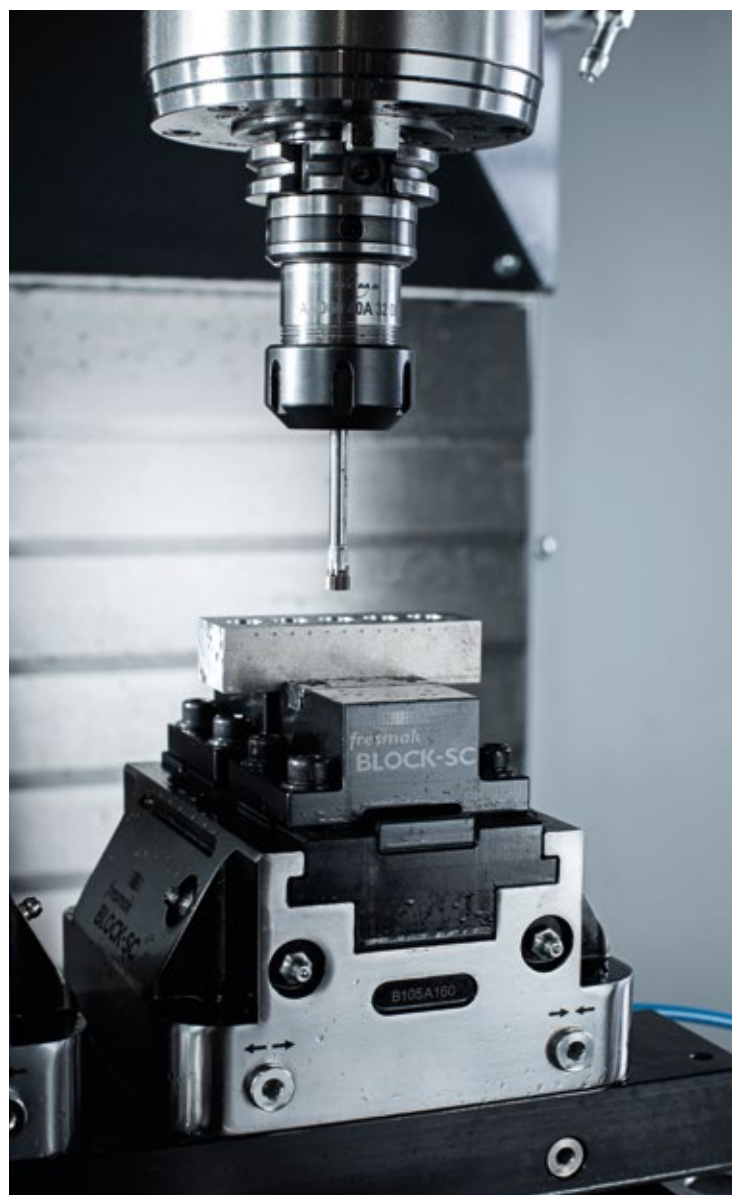

Size	Code	Gripping force kN	Max. operating pressure bar	Jaw stroke mm	Repeatability mm	Max. jaw height mm	Oil consumption cm <sup>3</sup>	Weight Kg
HYDRAULIC 100	122000100	16	120	6	0,01	60	30	5
HYDRAULIC 160	122000160	40	120	8	0,02	60	90	14

\* The total clamping strength of BLOCK-SC is the sum of the individual strengths of each jaw.



# BLOCK-SC HYDRAULIC

Hydraulic 100

Code 122 000 100

## DIMENSIONS

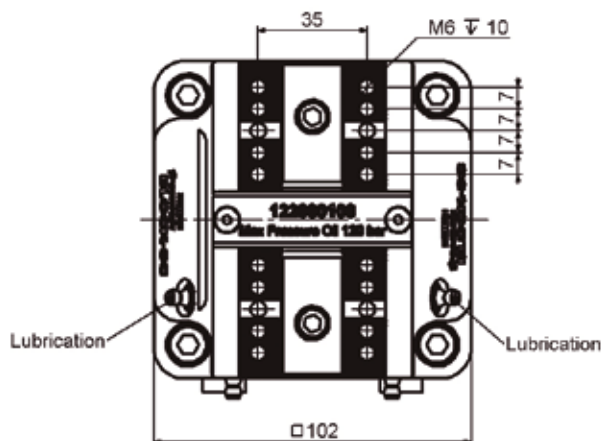
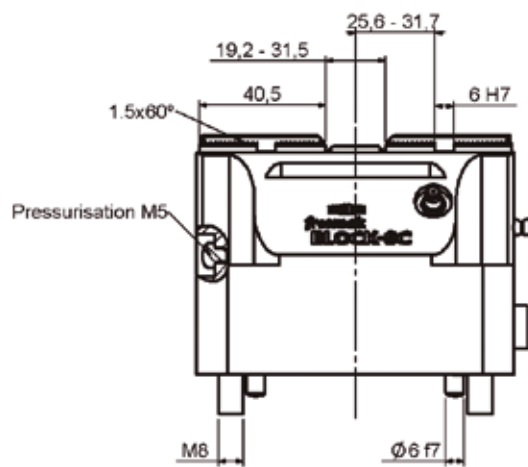
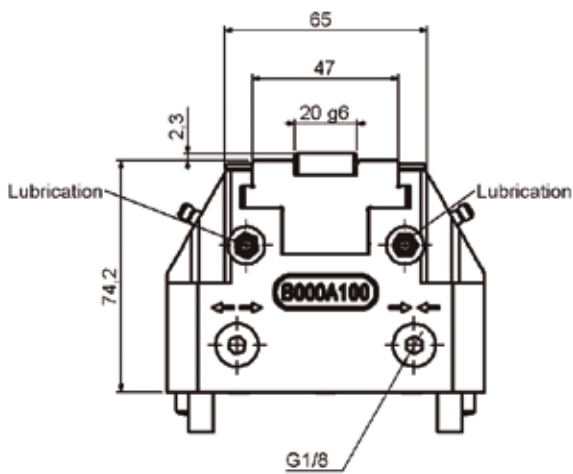
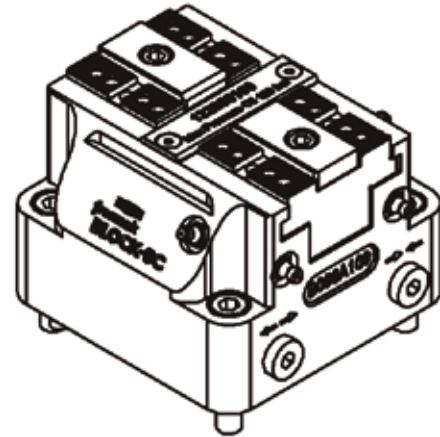
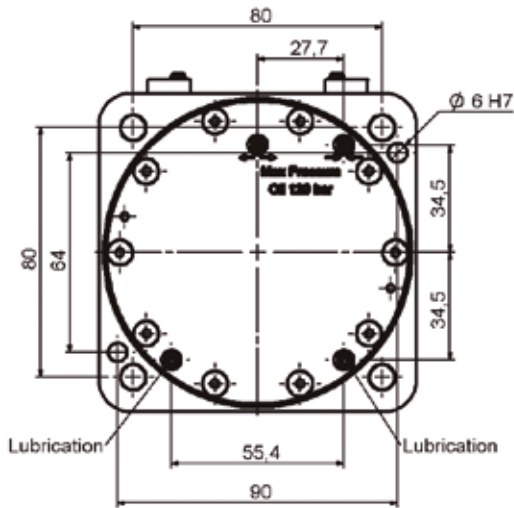

# BLOCK-SC HYDRAULIC

## Hydraulic 160

Code 122 000 160

### DIMENSIONS

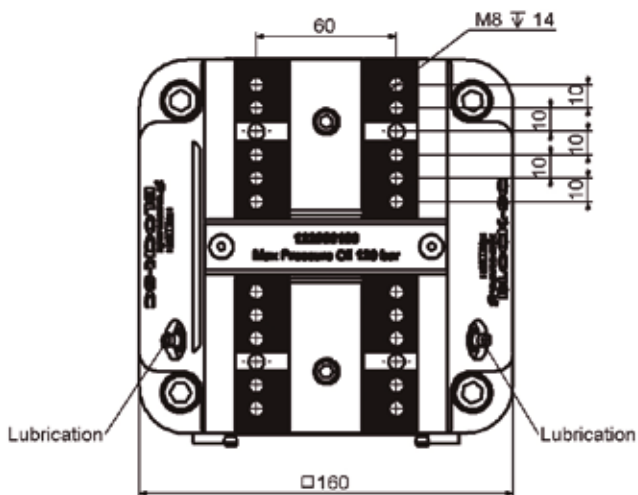
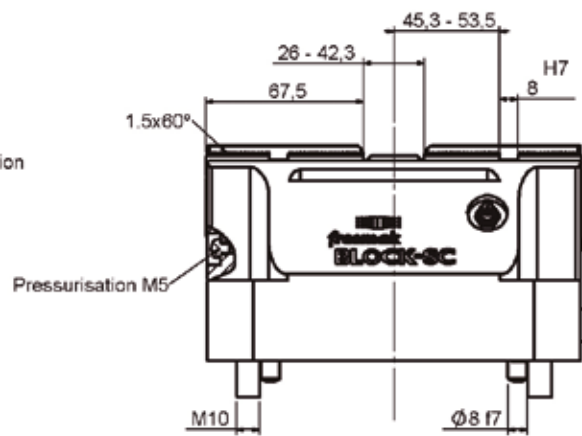
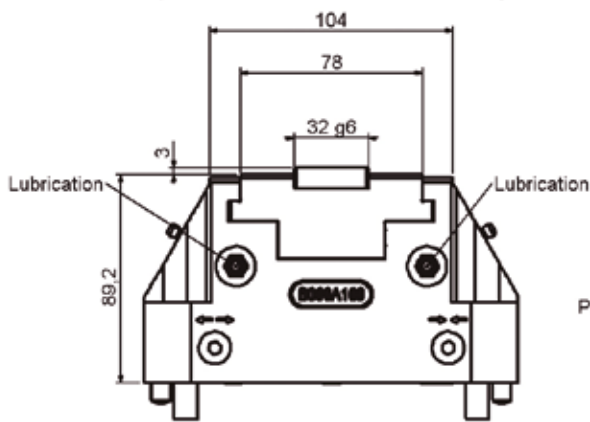
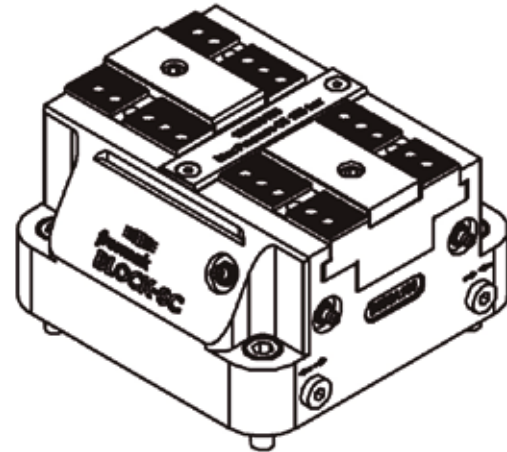
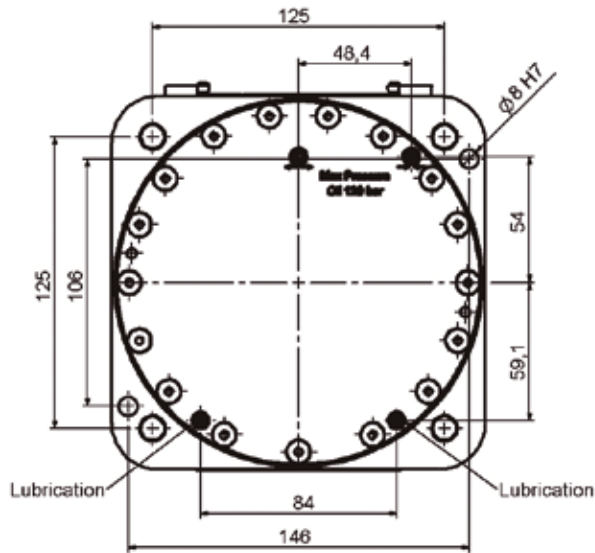

# BLOCK-SC Pneumatic



Pneumatic **BLOCK-SC** static blocks reach a pressure up to 20 KN with an infeed power of 9 bar.

## SET SUPPLIED

- Body
- 2 body dowel pins
- 4 screws
- Service manual

## FUNCTIONING

→ Pneumatically driven wedge clamping system: the multiplication of the pneumatic force is performed by actioning the wedge.



## FEATURES

- > Stroke range of 6 and 8mm.
- > Double effect actinoning.
- > Long guides.
- > All basic components are hardened.
- > Basic surfaces are ground.
- > Entirely compact and fully protected against chips.
- > Total lubrication system. Greasing channels within the base jaw and base body.
- > The air supply for machining and lubrication can be performed from the sides or the base of the body.
- > Pneumatic supply up to 9 bar.

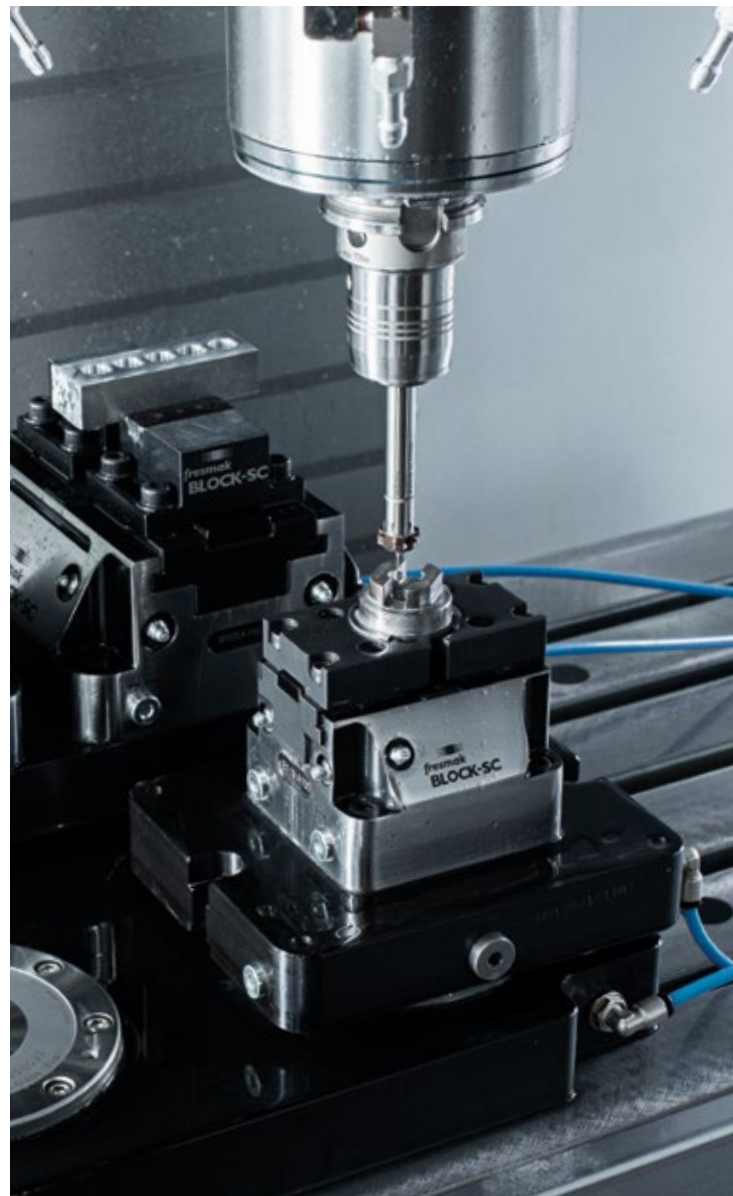

Size	Code	Gripping force kN	Max. operating pressure bar	Jaw stroke mm	Repeatability mm	Max. jaw height mm	Oil consumption cm <sup>3</sup>	Weight Kg
PNEUMATIC 100	162000100	8	9	6	0,01	150	160	4,5
PNEUMATIC 160	162000160	20	9	8	0,02	200	500	12,5

\* The total clamping strength of BLOCK-SC is the sum of the individual strengths of each jaw.

# BLOCK-SC PNEUMATIC

Pneumatic 100

Code 162 000 100

## DIMENSIONS

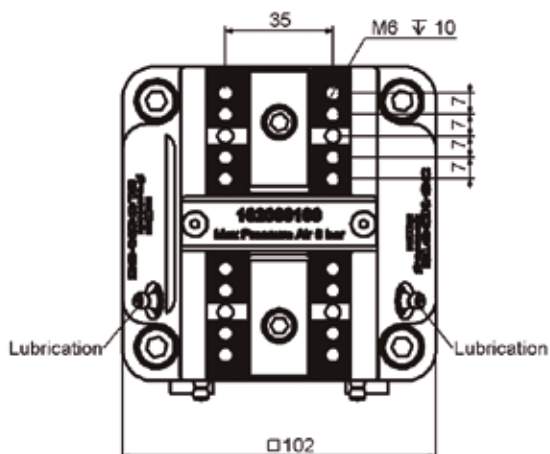
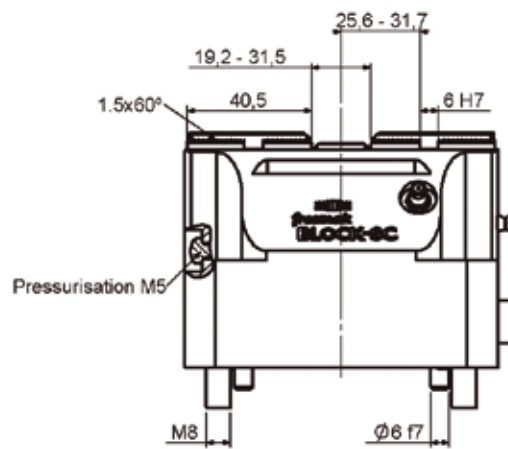
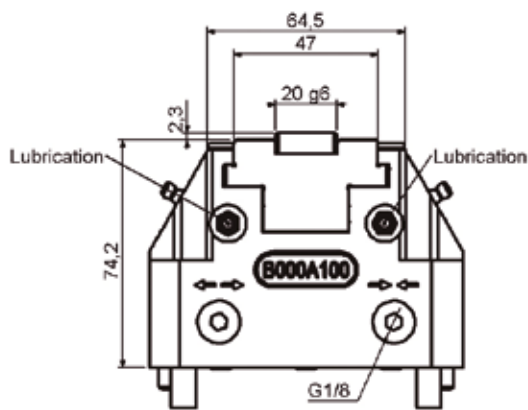
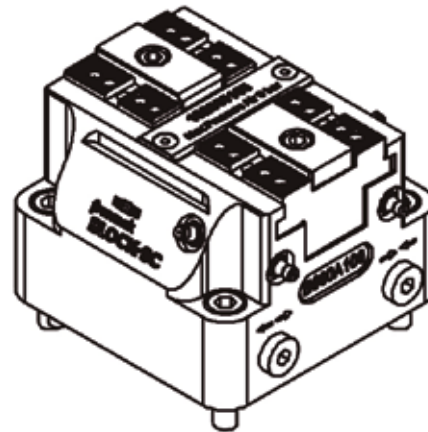
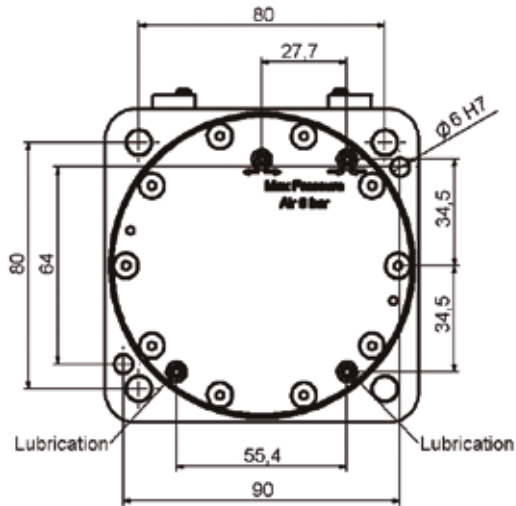

# BLOCK-SC PNEUMATIC

## Pneumatic 160

Code 162 000 160

### DIMENSIONS

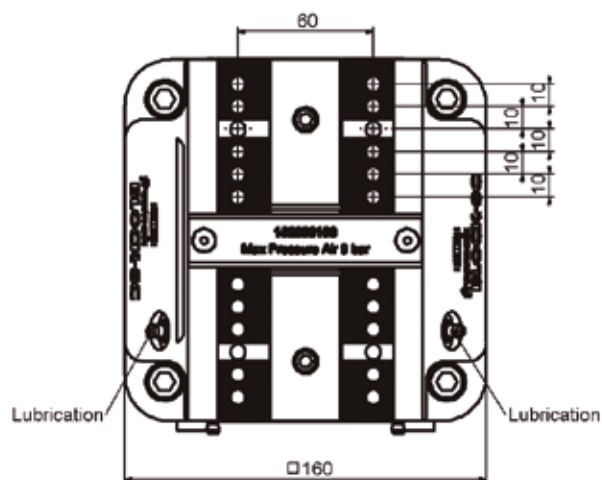
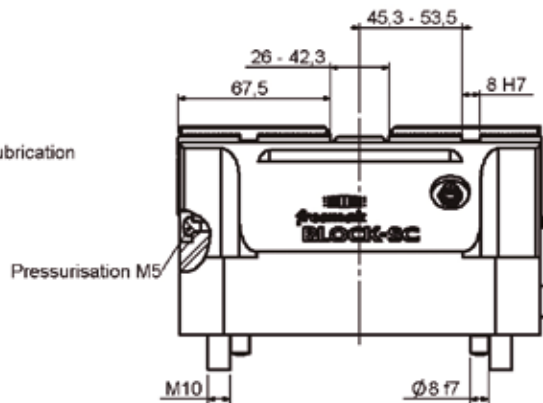
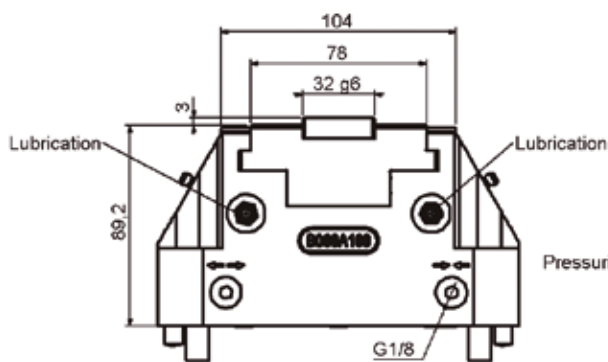
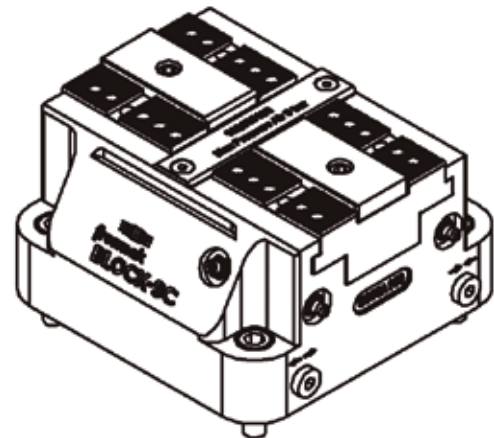
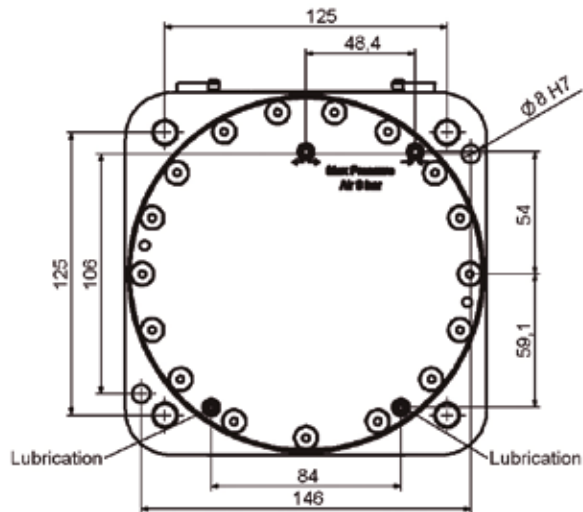



## PARTS AND ACCESSORIES

### JAWS

- > 3 sets of jaws for each model of BLOCK-SC available, designed to be machined according to the geometry of the work piece.
- > Fast and accurate change of jaws.
- > Carved or with keyways within the jaws (depending on the jaw).
- > Different work pieces can be clamped just by changing the jaws.

#### → Wide jaw

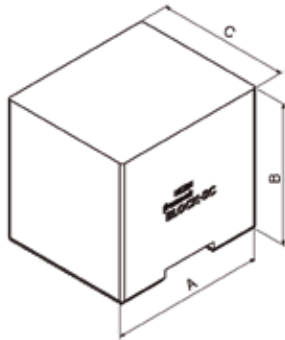

### FEATURES

- > **Jaw** Soft jaw
- > **Material** F-1550 (18crMoS4)  
Can be hardened
- > **Assembly** Carved 1.5 x 60°

Code	A	B	C
192231100	55	50	47
192231160	80	80	76

#### → Narrow jaw

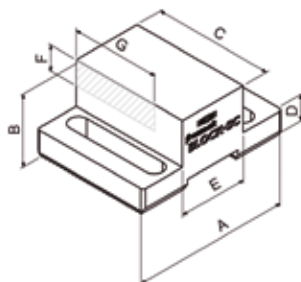

### FEATURES

- > **Jaw** Soft jaw, slotted
- > **Material** F-1550 (18crMoS4)  
Can be hardened
- > **Assembly** Carved 1.5 x 60°

Code	A	B	C	D	E	F	G
192230100	55	25	42	9	24	9	31
192230160	80	40	60	12	45	19	40

## PARTS AND ACCESSORIES

### JAWS

→ Jaw with keyways

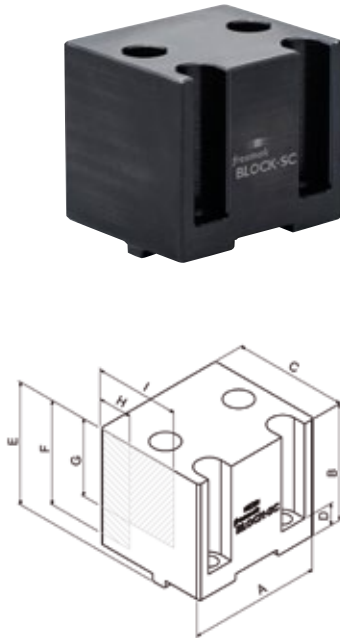

### FEATURES

- > **Jaw** Soft jaw with fixing holes
- > **Material** F-1550 (18crMoS4)  
Can be hardened
- > **Assembly** Keyways

Code	A	B	C	D	E	F	G	H	I
192232100	55	48	47	9	50,6	43	32	14	35
192232160	80	77,5	80	12	80,5	70	57	28	51

### CUSTOMIZED JAWS

> Tailor made jaws upon request.

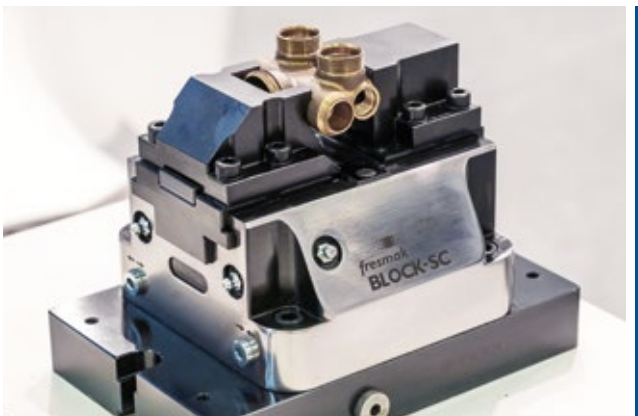



## PARTS AND ACCESSORIES

### PLATES

The BLOCK-SC can be fed from the side or from the base.

When being fed by the base, it is necessary to place the BLOCK-SCs on an auxiliary plate that supports them and allows to drill holes inside to drive the oil or air.

These plates can be used for one, two or three BLOCK-SC side by side; more units under request. This type of internal feed enables placing as many BLOCK-SCs as possible in the smallest space, which increases the productivity of this clamping system.

### Plates for Hydraulic BLOCK-SC

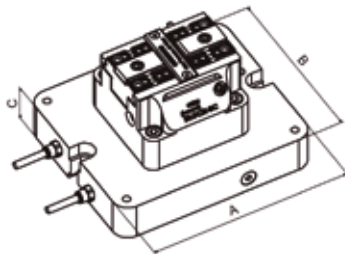

#### → Single

Code	A	B	C
182001100	190	160	36
182001160	240	160	36

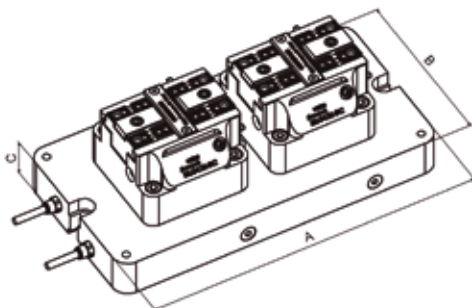

#### → Double

Code	A	B	C
182002100	315	160	36
182002160	420	160	36

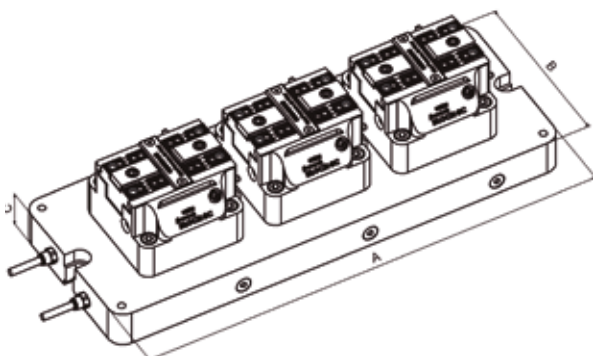

#### → Triple

Code	A	B	C
182003100	440	160	36
182003160	600	160	36



## PARTS AND ACCESSORIES

### PLATES

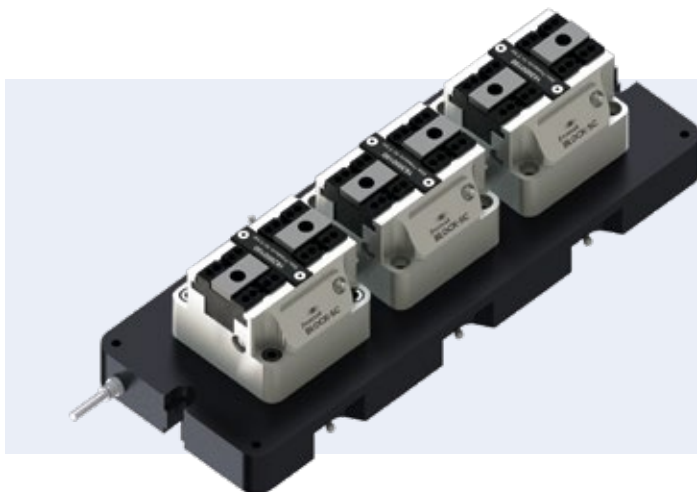

### Plates for Pneumatic BLOCK-SC

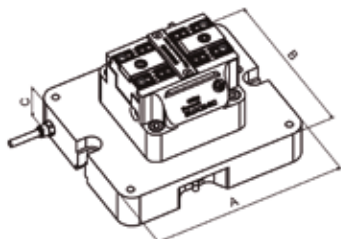

#### → Single

Code	A	B	C
186001100	190	160	36
186001160	240	160	36

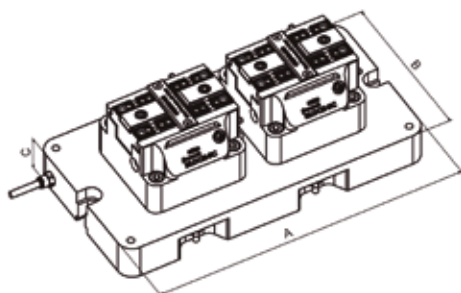

#### → Double

Code	A	B	C
186002100	315	160	36
186002160	420	160	36

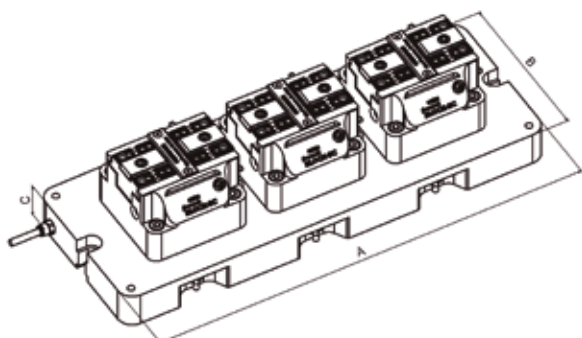

#### → Triple

Code	A	B	C
186003100	440	160	36
186003160	600	160	36

## PARTS AND ACCESSORIES

### TAILOR MADE

- > Available upon request.
- > BLOCK-SC can be equipped with additional accessories such as non-return valves.

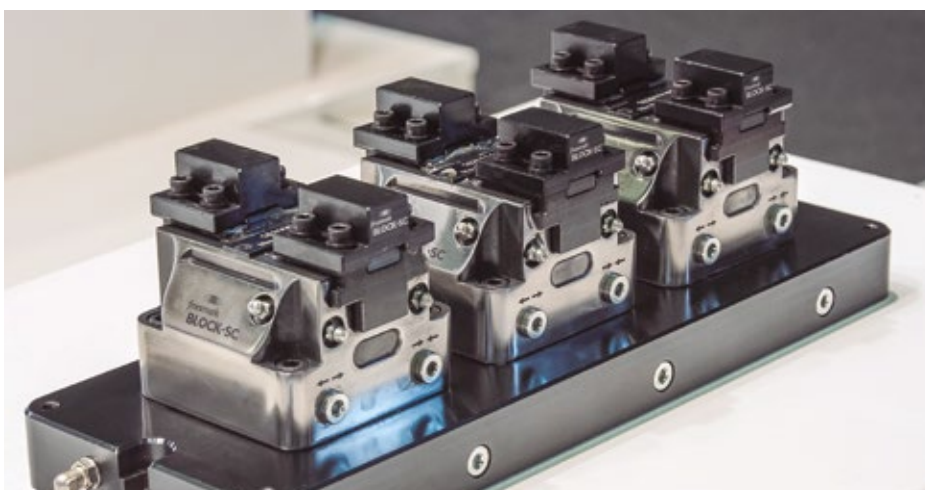
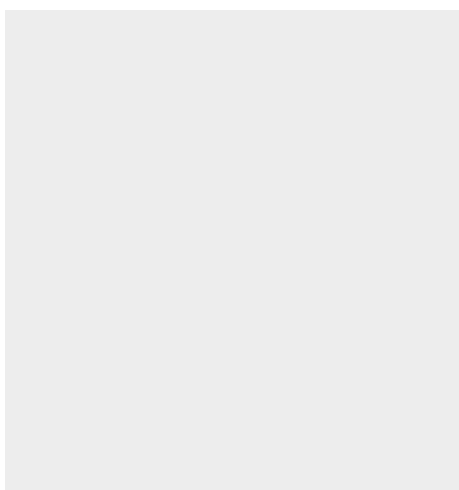

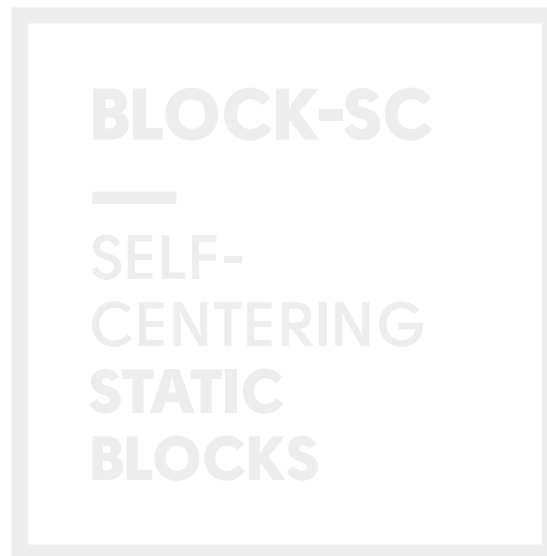



**fresmak**  
**BLOCK-SC**

[www.fresmak.com](http://www.fresmak.com)



**fresmak**

## CLAMPING SOLUTIONS

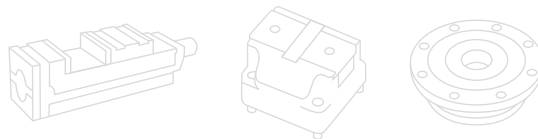

---

**Fresmak S.A.**  
Araba Kalea, 45  
20800 Zarautz (Gipuzkoa) · Spain

Tel.: (+34) 943 834 250  
Fax: (+34) 943 830 225  
[fresmak@fresmak.com](mailto:fresmak@fresmak.com)